

MINIATURIZED MICROPARTICLE TRAPPING SETUP WITH VARIABLE FREQUENCY

O. S. STOICAN, B. MIHALCEA, VIORICA GHEORGHE

*National Institute for Laser, Plasma and Radiation Physics
Bucharest–Magurele, P. O. Box MG-36, Romania*

(Received July 25, 2001)

Abstract. A miniaturized microparticle trapping setup with variable frequency is reported. The setup is intended to be used in order to study the trapping phenomenon for charged microparticles in quadrupolar electromagnetic fields and to achieve stable ordered structures.

Key words: electromagnetic quadrupolar trap, micoparticles confinement, ordered structures.

1. INTRODUCTION

The setup we designed and realized allows to study the trapping phenomenon of charged microparticles in quadrupolar electromagnetic traps and the appearance of stable, ordered structures. A simple and low-cost trapping setup can help in drawing conclusions about charged particle evolution in an ion trap. The laws describing the trapped microparticle motion in air are almost identical with those accounting for stored atomic ion motion in ultrahigh vacuum. Microparticle breaking *via* air friction is analogous with ion cooling *via* buffer gas molecules collision.

The setup is equipped with two trap geometries: a linear one and an annular one. The linear trap (with a fixed length) consists of four parallel metallic rods and two “endcap” electrodes. Upon request, a linear trap with variable length can be realized. The annular trap comprises one central electrode and two “endcap” electrodes, coaxially arranged. Depending on the trap geometry, different patterns of ordered structures (planar and linear strings, zigzag structures) can be observed with bare eyes. The diagnosis of a trapped microparticle is achieved by means of a d.c. voltage with known polarity.

Experimental setups for microscopic particles confinement in Paul traps, operating at standard temperature and pressure (STP) and 50 Hz frequency, targeted for mass and charge, vapour pressure, viscosity and surface tension measurements or for didactical demonstrative purposes, have been previously reported [1],[2]. For other possible applications, working with a variable length

linear trap at STP conditions, for different drive frequencies, is expected to yield important results. In [3], several experimental results achieved with such a variable trap are reported.

2. TECHNICAL DESCRIPTION

The setup consists of the following main blocks:

- 1) the particle trap with two different geometries (linear and annular geometry, respectively);
- 2) the electronic supply block generating the a.c. variable frequency trapping voltage, the d.c. trapping voltages and the a.c. parametrical excitation voltage;
- 3) the trapped particles illumination system.

The linear geometry trap consists of four parallel brass rods (Fig. 1), equidistantly spaced on an approximately 10 mm radius, and two “endcap” electrodes. The rod diameter and length are 10 mm and 70 mm, respectively. The distance $2z_0$ between the upper and lower trap electrodes is 10 mm.

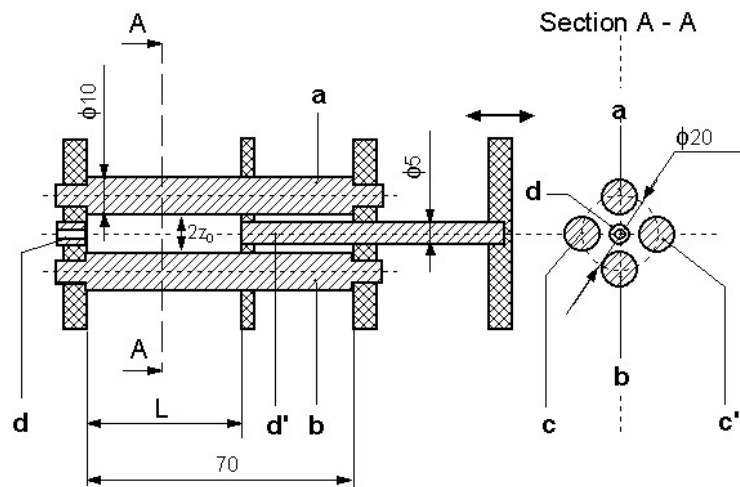
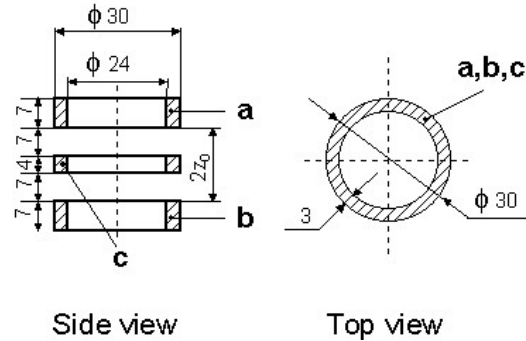

Fig. 1 – Sketch of the linear trap geometry.

The annular geometry trap comprises one central cylindrical electrode and two annular “endcap” electrodes (Fig. 2). The two annular “endcap” electrodes are covered with a thin metallic grid for certain versions of the setup. The annular electrodes inner diameter and thickness are 24 mm and 7 mm, respectively. The distance $2z_0$ between the upper and lower trap electrodes is 25 mm.

Fig. 2 – Sketch of the annular trap geometry.



The electronic supply unit (Fig. 3) delivers the following trapping voltages applied on the trap electrodes:

- An a.c. variable voltage U_{ac} (0 - 2.5 kV), with variable frequency $\Omega/2\pi$ in the 50-800 Hz range;
- A parametrical excitation variable voltage U_{ext} (0-250 V), with variable frequency $\omega/2\pi$ in the 0-250 Hz range;
- A d.c. diagnosis voltage with switching polarity U_z , whose range lies between 0 and 700 V;
- A d.c. voltage U_x , needed for axial confinement (only for linear trap) whose range lies between 0 and 700 V.

The O1 oscillator delivers an a.c. voltage of $\Omega/2\pi$ frequency (drive frequency) and the O2 oscillator delivers an a.c. voltage of $\omega/2\pi$ frequency. Both voltage amplitudes are variable. An operational amplifier adds the two voltages, while the resulting signal is applied to the input of a power amplifier. The high voltage transformer block rises up the a.c. voltage delivered from the output of the power amplifier (max. 6 V_{RMS}) to a 2.5 kV value.

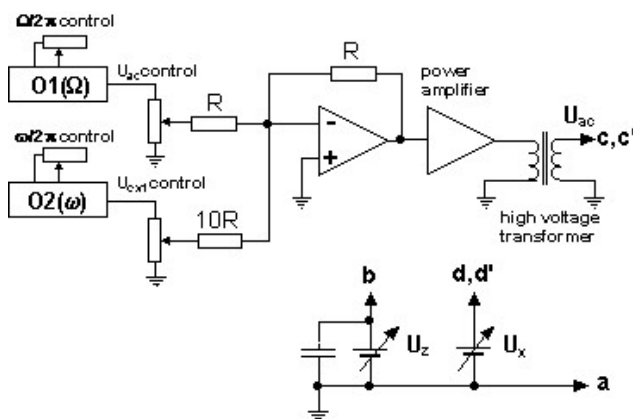

Fig. 3 – Power supply unit–block diagram.

A 3-digit display placed on the front panel of the setup displays the values of the $\Omega/2\pi$, $\omega/2\pi$ frequencies and of the U_{ac} , U_z or U_x voltages. The whole setup forms a single block .

The trap illumination system contains a halogen lamp (220 V, 50 Hz, 20 W) common for both traps and a laser diode which assures illumination along the horizontal axis (*x-axis*) only for the linear trap.

Trapped microparticles can be observed with bare eyes, eventually using a magnifying lens.

The electronic supply unit is connected to the main power supply 220V/50Hz. The power consumption does not exceed 50 W. The whole setup weight is about 15 kg.

3. THEORY AND RESULTS

The a.c. voltage U_{ac} with $\Omega/2\pi$ frequency (drive frequency) is applied between the (c),(c') and (a), (b) electrodes, in order to achieve microparticle confinement. A d.c. voltage U_z is applied between the (a) and (b) electrodes, thus shifting the microparticle position along the vertical axis. In the case of the linear trap, a d.c. voltage U_x is also applied between the (d), (d') electrodes and the ground.

The equation of motion for a particle of mass M and charge Q within the trap volume is:

$$\mathbf{F} = Q\mathbf{E} - Kd\mathbf{r}/dt + M\mathbf{g} + QE_z \quad (1)$$

where $\mathbf{r} = (x, y, z)$ is the particle vector position, x, y, z are the particle coordinates and K ($K > 0$) represents the coefficient describing the aerodynamical drag force. \mathbf{E} is the electric field produced by the a.c. voltage, $M\mathbf{g}$ is the gravitational force and $E_z = U_z/2r_0$ is the magnitude of the electric field produced by applying a static potential difference U_z between the upper and lower trap electrodes, separated at $2z_0$, in order to shift the particles towards the trap center. We introduce the $\tau = \Omega\tau/2$ and $A = K/M\Omega$ parameters, where Ω is the drive angular frequency. By defining $X = e^{At}x$, $Y = e^{At}y$ and $Z = e^{At}z$, the Mathieu equations describing the trapping process are homogeneous on the X and Y axes, with the well-known solutions and stability domains [4]. The z -axis motion is described by an inhomogeneous Mathieu equation. In this case, the stability regions for solutions of the inhomogeneous equations of motion in the presence of drag forces include not only the stability regions of the homogeneous equations, but also a part of the instability regions, being consequently larger. One up to thousands of microparticles can be trapped along the trap axis. Fig. 4 shows some of the ordered structures (planar, zig-zag and volume structures) we obtained within the linear trap volume.

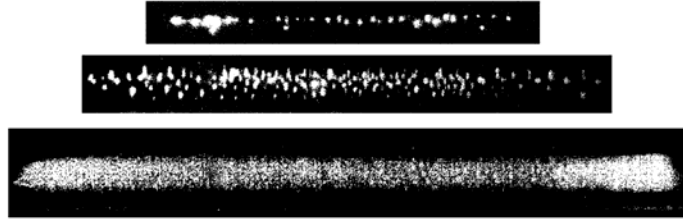

Fig. 4 – Ordered structures photographed inside the linear trap.

Depending on the trap length and N microparticles number, different inter-microparticle distances are obtained (Fig. 5). SiC powder was used, with homogeneous, well-defined dimensions rating between 50-1000 μm [6].

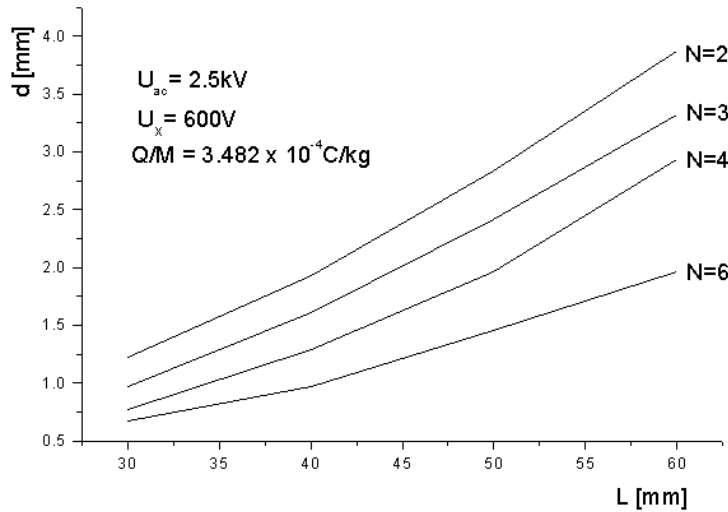

Fig. 5 – Interparticle distance dependence on trap length L and particle number N .

By varying the U_x and U_z voltages, trapped microparticles can be manipulated, from left to right and upside-down, respectively. When a microparticle is placed in the center of the trap by means of the applied U_z voltage, it can be shown that [5]:

$$Q/M = 2gz_0/U_z \quad (2)$$

where $g = 9.81 \text{ m/s}^2$. This formula allows us to estimate the specific charge for different trapped microparticle species. Specific charge mean values for the various trapped species we used, are shown in Table 1.

Table 1

Specific charge mean values for the various trapped species

Material	SiC	Anthracene	Alumina	Hydroxyl apatite
$\bar{Q} / \bar{M} \times 10^4$ [C/kg]	3.482	2.974	4.147	4.873

Usually, parametrical excitation is achieved for trapped microparticle motion by applying a low amplitude and variable frequency supplementary a.c. voltage in series with the U_{ac} voltage. When the supplementary a.c. field frequency is twice that of the secular motion, microparticles (located at the limit of the first Mathieu domain) resonantly absorb energy from the field, while their secular motion amplitude exponentially increases. If the trap contains a number of noninteracting particles, besides normal resonance at the secular motion frequency and parametrical resonance at the double secular motion frequency, other weak resonances were observed, as a consequence of coupled terms presence for various combinations of motion frequencies.

4. CONCLUSIONS

The setup is intended to be used in order to study the trapping phenomenon for charged microparticles in quadrupolar electromagnetic fields and to achieve stable ordered structures. The setup is delivered together with a diskette comprising a simulation program, which illustrates the microparticle ordering phenomenon. Until now, the setup has been delivered to the Technical University, Poznan, Poland, to the "J. Gutenberg" University in Mainz, Germany and to the University of Bucharest, Romania.

Acknowledgment. The authors acknowledge support from the National Agency for Science and Innovation (ANSTI): Grants 5086/1999, 5087/1999-2000 and Grant 6157/2000.

REFERENCES

1. H. Winter, H. W. Ortjohann, *Am.J.Phys.*, **59**, 807 (1991).
2. S. Arnold, L. M. Folan, A. Korn, *J.Appl. Phys.*, **74**, 4291 (1993).
3. V. N. Gheorghe, L. C. Giurgiu, O. S. Stoican, D. Cacicovschi, R. Molnar, B. Mihalcea, *Acta Physica Polonica A*, **93**, 625 (1998).
4. N. W. McLachlan, *Theory and Application of Mathieu Functions*, Oxford University Press, New York, 1947.
5. E. J. Davis, A. K. Ray, *Journal of Colloid and Interface Science*, **70**, 556 (1980).
6. V. N. Gheorghe, L. Giurgiu, O. S. Stoican, B. Mihalcea, D. Cacicovschi, S. Comanescu, *Proc 28th EGAS Conference, Graz, 16-19 July 1996, Abstracts D4-09, p. 444.*